

# Diablo Ver-2.1(改定1)

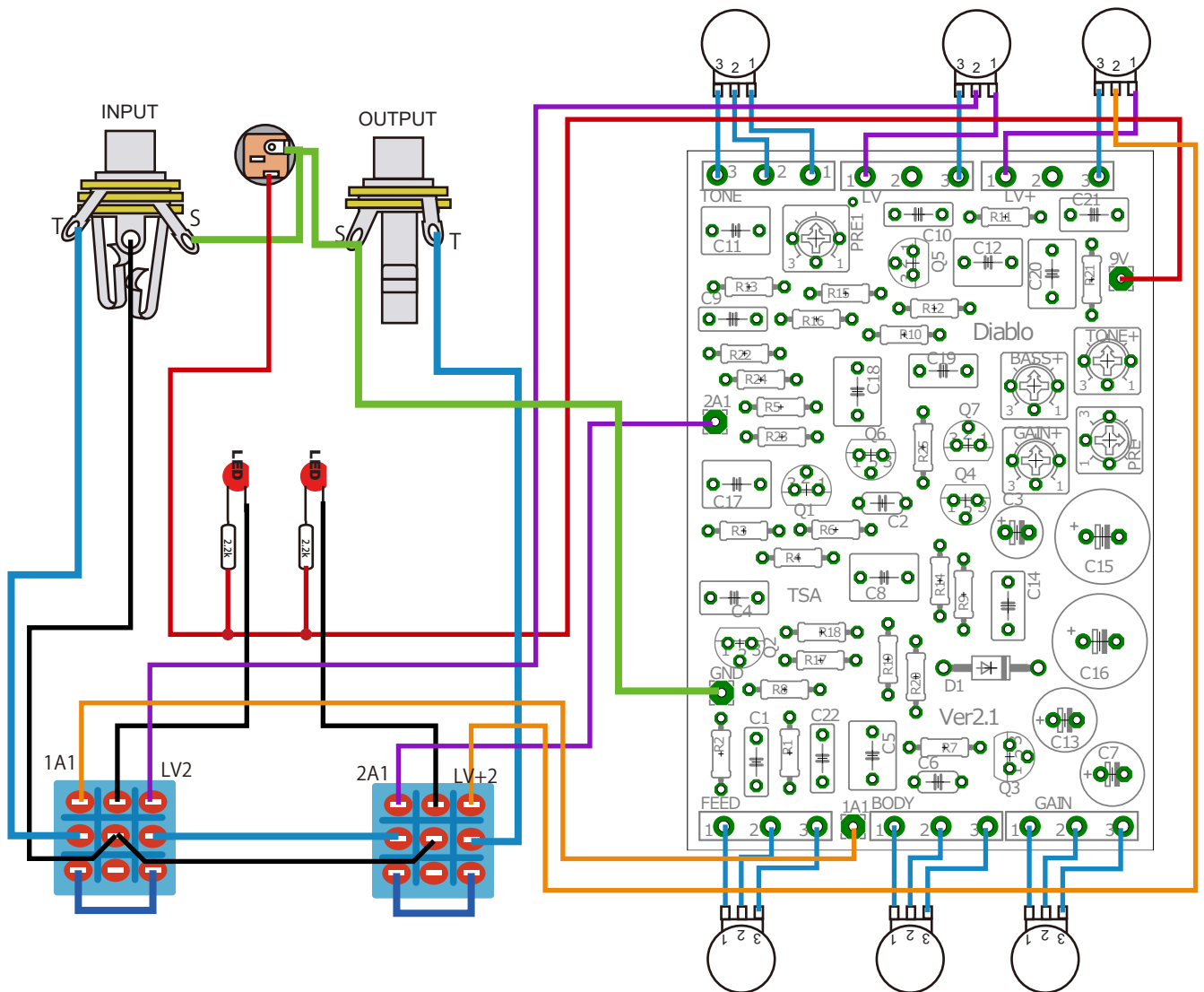

BODY	1MB	R1	1M	R12	39k	C1	0.0033u	C14	0.01u
FEED	1MB	R2	10k	R13	43k	C2	470p	C15	100u(電解)
GAIN	500KA	R3	1M	R14	470k	C3	10u(電解)	C16	100u(電解)
TONE	100KB	R4	47k	R15	1M	C4	0.047u	C17	0.1u
LV	100KB	R5	1k	R16	3.3k	C5	0.1u	C18	1u
LV+	100KB	R6	1k	R17	470k	C6	470p	C19	0.01u
D1	1N4007	R7	10k	R18	470k	C7	47u(電解)	C20	0.1u
LED1	LED	R8	100R	R19	10k	C8	1u	C21	0.047u
LED2	LED	R9	1k	R20	10k	C9	0.0033u	C22	0.001u
PRE	100k(半固定)	R10	47k	R21	100R	C10	0.0082u		
TONE+	100k(半固定)	R11	1M	R22	1M	C11	0.1u		
PRE1	100k(半固定)			R23	10k	C12	0.1u		
GAIN+	5k(半固定)			R24	1M	C13	47u(電解)		
BASS+	5k(半固定)			R25	1k				
Q1	J201								
Q2	J201								
Q3	J201								
Q4	J201								
Q5	J201								
Q6	J201								
Q7	J201								

2.1mmDCジャック(3端子)  
6.35mmステレオジャック  
6.35mmモノラルジャック  
9ピン3PDTフットSW  
8ピンICソケット  
SW用LED&抵抗(2.2k~3.3k)

音色研究会